



...Display, Control, Communicate



Tutorial

Analogue I/O

Table of Contents

Table of Contents	2
Introduction.....	3
Analogue I/O type selection.....	4
Hardware Configuration	4
Software Configuration.....	6
Programming the Analogue I/O.....	8
Programming Example	8
Configuring the I/O.....	8
Ladder Logic Programming	9
Screen Editor Configuration	10

Introduction

The purpose of this tutorial is to demonstrate the Analogue input / output capabilities of the i^3 . This tutorial will also display how to use the scaling function.

The i^3 integrated controller can, depending on the model chosen have up to 4 analogue inputs as with model i3A12X/10D03-SCH or, in the case of model i3A12X/13C14-SOH, have 2 analogue inputs and 2 analogue outputs.

The resolution of the individual I/O points is also dependant on the model selected. This ranges from 10 bit to 14 bit resolution for inputs and 12 bit resolution output for the outputs. The analogue value is represented by an integer value 0 - 32,767. An important point to remember is that the %AQ registers have other uses, i.e. they are used in setting up the PWM output and therefore the two physical outputs on the model i3A12X/13C14-SOH are addressed at %AQ09 and %AQ10.

Analogue I/O type selection

Hardware Configuration

The i^3 can have both voltage (0-10Vdc) and current (0-20mA and 4-20mA) input and output. To select the desired input, there are some hardware setting and software setting. Jumper pins need to be set that are located inside the casing, to access these jumpers, the back section of the case needs to be removed as shown in Figure 1.

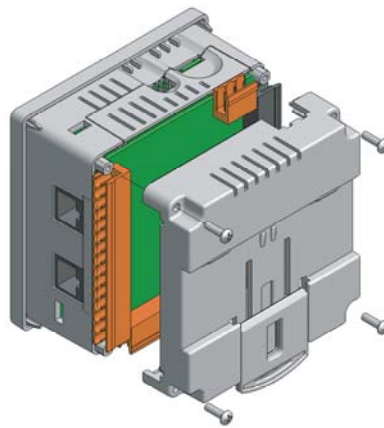
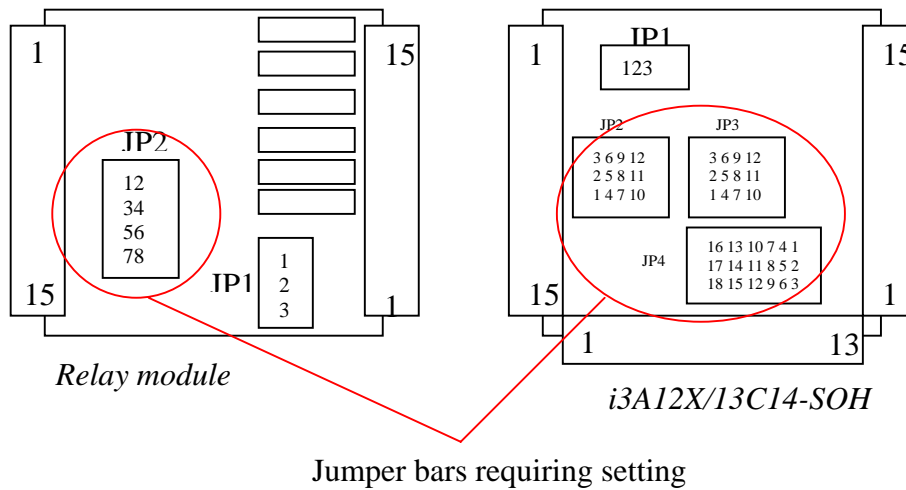

Figure 1: Removing the i^3 Cover



Function JP2	i3A12X/10A01-SOO 20mA	i3A12X/10D03-SCH 20mA	i3A12X/10B04-SCH 20mA	i3A12X/20B05-SOH 20mA	i3A12X/13C14-SOH 20mA	All 10V
Channel 1	1-2	1-2	1-2	1-2	1-2	Open
Channel 2		3-4	3-4	3-4	3-4	Open
Channel 3		5-6			5-6	Open
Channel 4		7-8			7-8	Open

Analogue I/O

i3A12X/13C14-SOH:

Link No.	Function	20mA	10V	PT100	Thermocouple
JP2	AI 1	8-9	8-9	2-3	1-2
		11-12	11-12	5-6	4-5
				7-8	7-8
				10-11	10-11
JP3	AI 2	8-9	8-9	2-3	1-2
		11-12	11-12	5-6	4-5
				7-8	7-8
				10-11	10-11
JP4	OUTPUT 1	1-2	2-3		
		4-5	5-6		
	OUTPUT 2	10-11	11-12		
		13-14	14-15		
		16-17	17-18		

Software Configuration

In the software (*i*³ configurator) the analogue I/O also needs to be set.

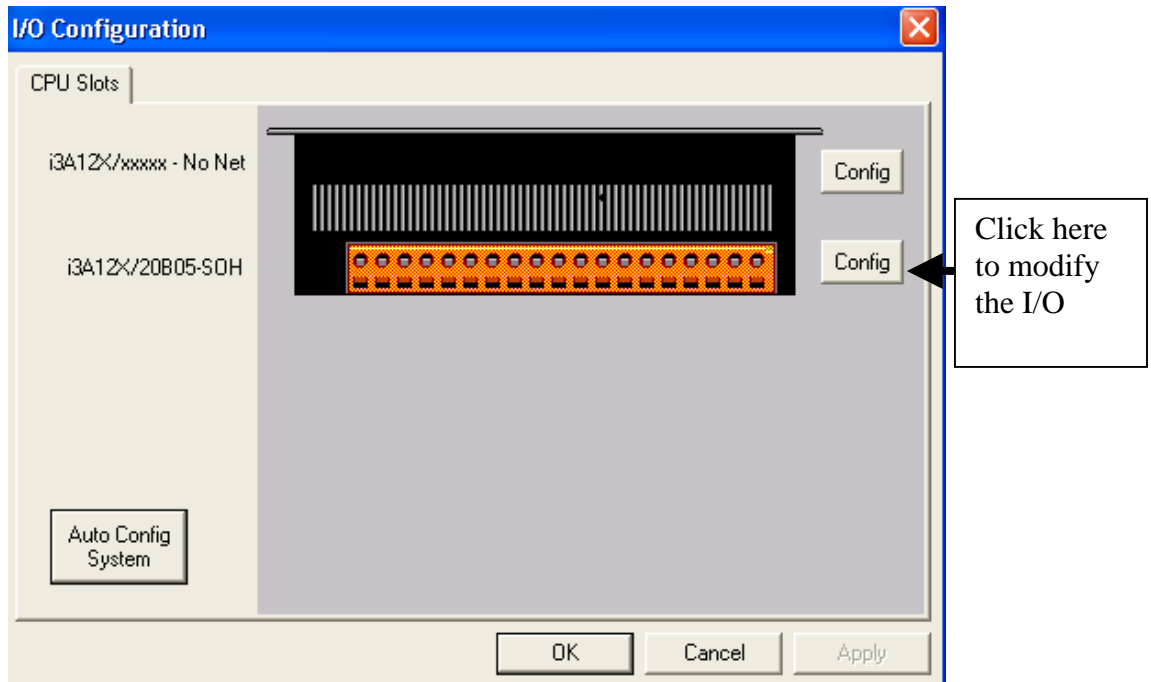
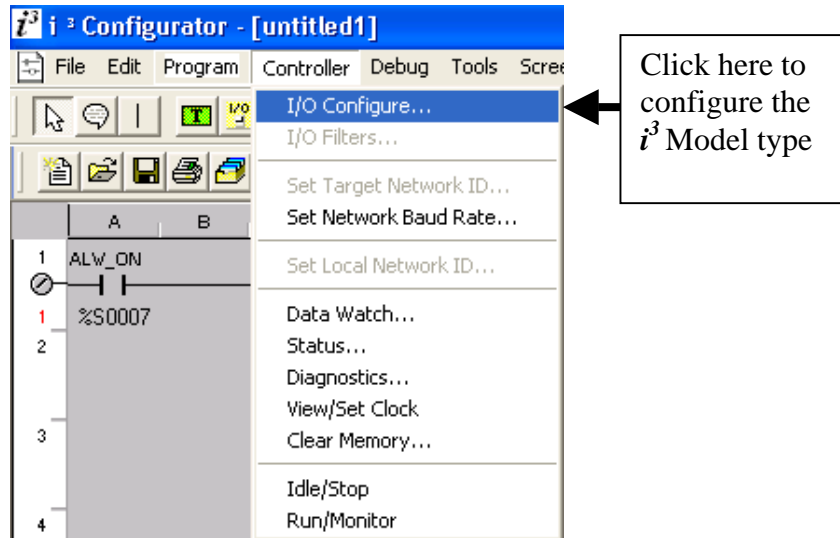

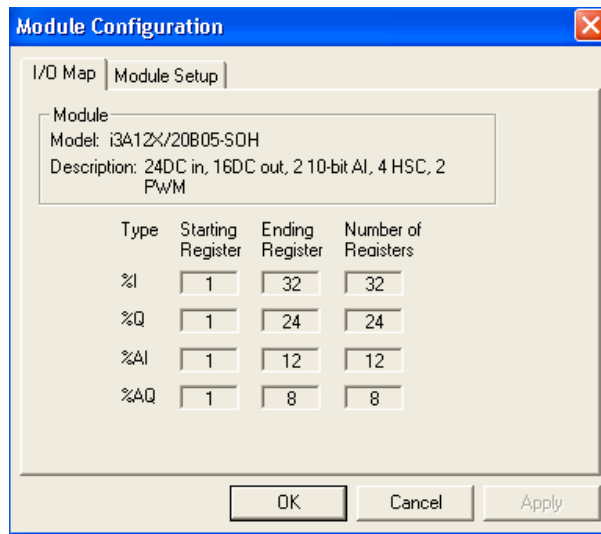

Click on the module set up

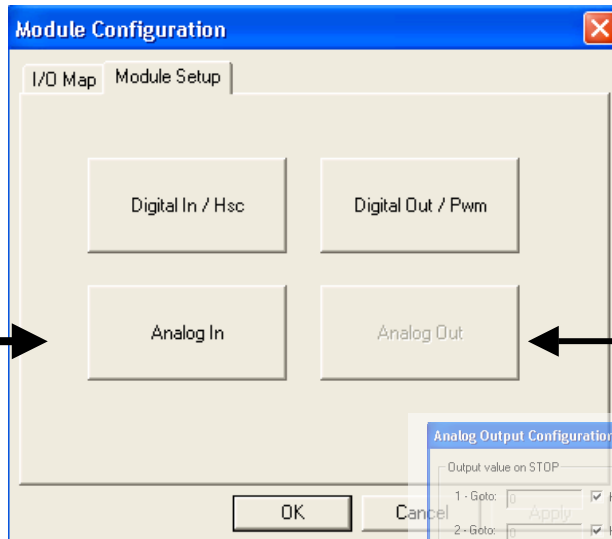

Click on the box to edit the details

On this model there is no Analogue output

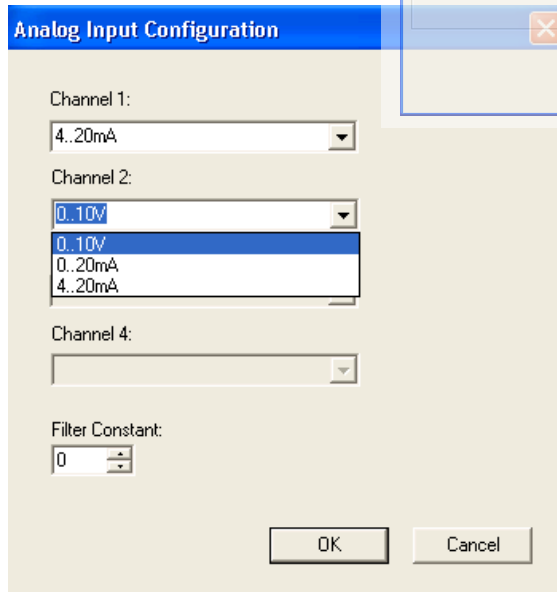
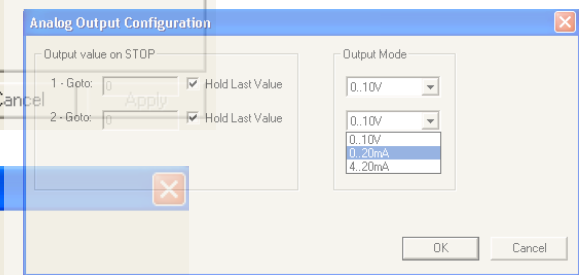

On this model we can select the type of input for two channels. The channels are independent and can be voltage or current

Click OK to confirm selection

Programming the Analogue I/O

Once the analogue inputs have been set to match the external inputs to the controller we can call the analogue inputs using the addressing structure.

%AI1 – Analogue input 1 } and so on
 %AQ9 – Analogue output 1 }

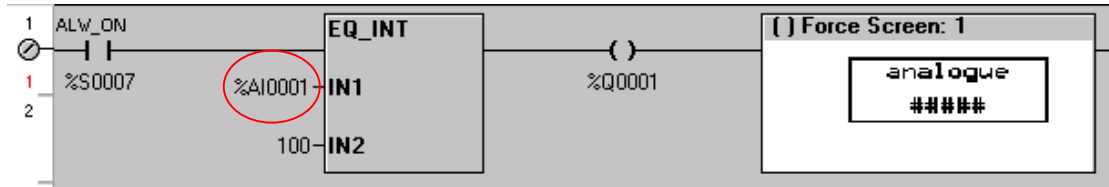

Programming Example

Configuring the I/O

For example we can use an i^3 to read in an analogue speed reference and output an analogue speed reference to an inverter drive.

The input and output will be scaled to 0-100%. The user will be able to input a speed reference (0-100%) to output to the drive.

Using the i3A12X/13C14-SOH, this unit has 2x14 bit analogue inputs and 2x12 bit analogue outputs. The input will be set to 4-20mA and the output will be set to 0-10V. Note the output addresses are %AQ9 and %AQ10.

First steps prior to programming

1. Set the Hardware jumper pins to the correct position.
 - a. Jumper JP2 Link 8-9 (20mA) AI1.
 - b. Jumper JP4 Link 2-3 (10V) AQ9.
 - c. Power up the i^3 .
2. Open i^3 Configurator and Configure the I/O
 - a. Controller Menu and select Config I/O
 - i. Auto Config System
 - ii. Configure the Analogue I/O

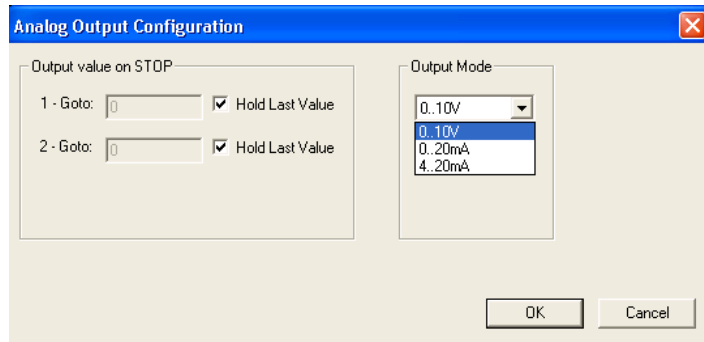
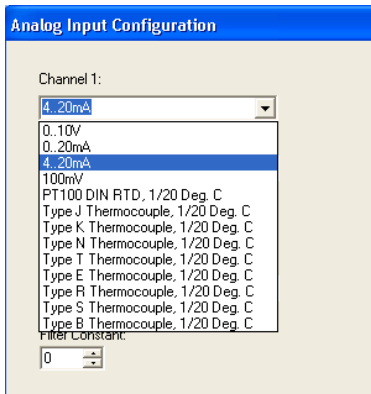

Now we can program the ladder logic.

Ladder Logic Programming

Select a N/O contact and insert it at A1. Assign the contact to the internal bit %S7, Always ON (ALW_ON).

Now select the scale function from the Advanced Maths Functions and insert it in the same rung as the %S7 N/O Always On (ALW_ON) contact.

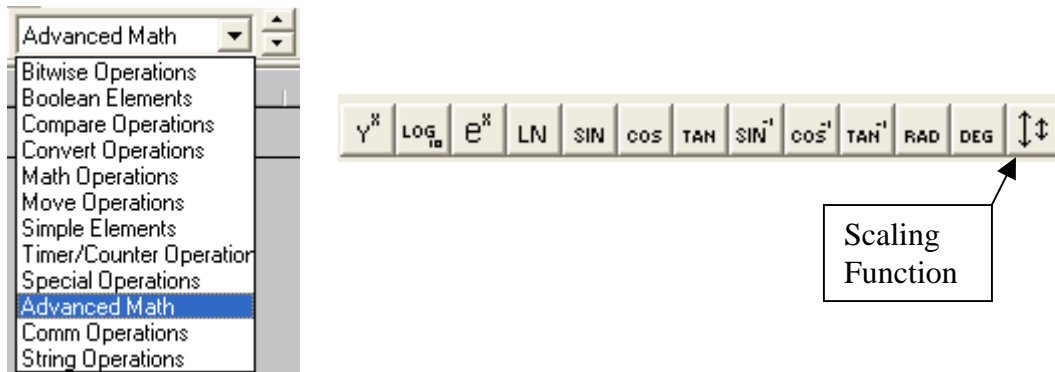

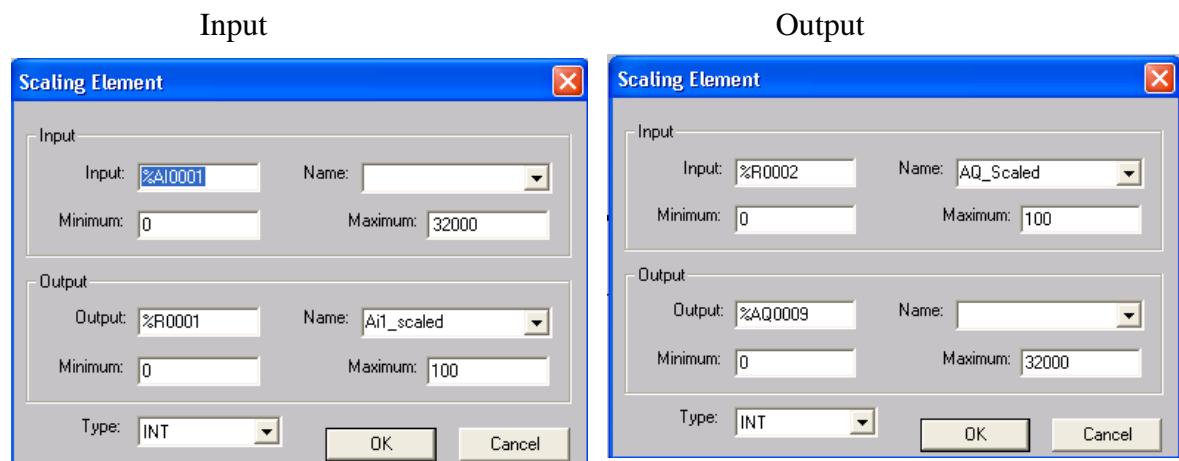

The analogue value ranges from 0 to 32676 and we want to scale the input to 0 to 100. Similarly with the output, we want to due the opposite.

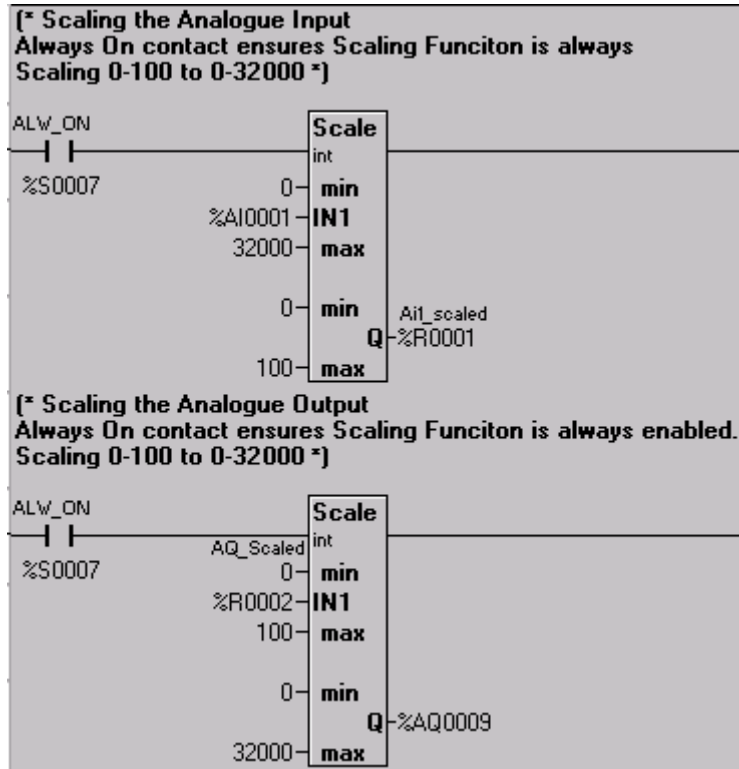

The analogue outputs register is also used for setting the PWM and the physical analogue outputs begin at %AQ09. Therefore for the model i3A12/13C14-SOH the analogue outputs will be %AQ9 and %AQ10.

The ladder logic should now look like this for both the analogue input and output scaling. To insert comments, right click in the margin of the Rung and select 'New Comment'.



If we now Error Check () the ladder program; we will find there are no errors. Now we are required to configure an initial screen. Click the Screen Editor icon .

Screen Editor Configuration

We are going to configure three screens:

1. Main menu
2. Input Speed, with actual input and scaled input
3. Output Speed, with a bar graph.

On the main menu we are going to enter 2 Screen Jump buttons, to jump to the input and output screens and a Static Text to display the title “Analogue Tutorial”

Screen Properties

Screen Jump 1	Screen Jump 2	Static Text
Address = 2	Address = 2	Font = San Serif 15
Attributes. No border or icon	Attributes. No border or icon	Text = “Analogue Tutorial”
Legend = AI	Legend = AQ	Text = Centred

Screen 1.

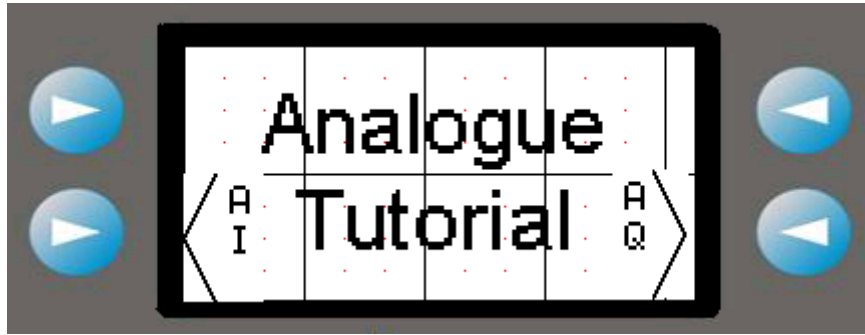

On the Analogue Input screen we are going to display the actual analogue value in %AI01, the scaled analogue value and a button to jump back to the main menu.

Screen Properties.

Numeric Data 1	Numeric data 2	Screen Jump
Address = %R01	Address = %AI01	Address = 1
Data Centred, Not Editable, 3 digits, % as engineering units	Data Centred, Not editable, 5 digits.	Attributes. Border and icon checked.
Legend = "I/P Speed Ref"	Legend = "AI1"	Legend = "Main"

Screen 2.





On the analogue output screen there is going to be a Jump Screen function to go back to the main menu, a numeric field to enter an output percentage for the speed reference and a bar graph to illustrate the percentage output.

Screen Properties.

Numeric Data	Bar Graph	Screen Jump
Address = %R02	Address = %R02	Address = 1
Data Centred, Editable, 3 digits, % as engineering units. Min = 0, Max = 100	Scale not displayed. Max = 100, Min = 0	Attributes. Border and icon checked.
Legend = "Output"	Legend = ""	Legend = "Main"

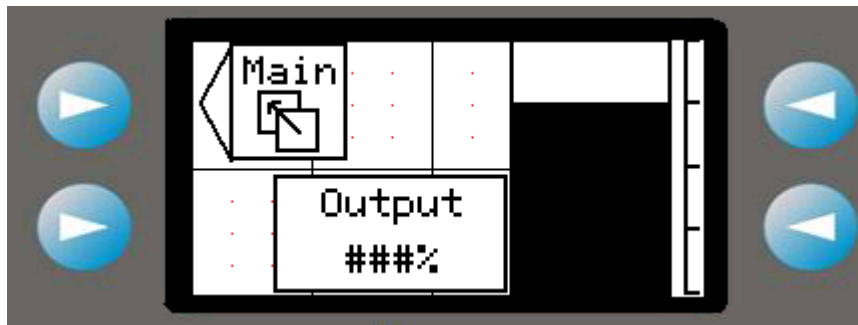
Screen 3.



A final Error Check, before exiting the screen editor. With no errors we can now download the program. .

After downloading the program, ensure you put the i^3 into RUN mode.

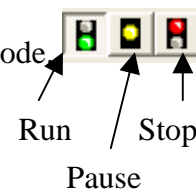

Please see the Program “ana_tut1.csp”



IMO Precision Controls Limited
 1000 North Circular Road
 Staples Corner, London
 NW2 7JP United Kingdom
 Tel: +44 (0)20 8452 6444
 Fax: +44 (0)20 8450 2274
 Email: imo@imopc.com
 Web: www.imopc.com



IMO Jeambrun Automation SAS
 165 Rue Jean Jaures,
 94700 Maisons Alfort
 Paris, France
 Tel: +33 (0)1 45 13 47 05
 Fax: +33 (0)1 45 13 47 37
 Email: info@imopc.fr
 Web: www.imopc.fr



IMO Deutschland
 Für weitere Einzelheiten
 zu IMO Agenten und
 Distributoren in Ihrer Nähe
 schreiben. Sie bitte ein E-mail
 an folgende Adresse:
 imo@imopc.com



IMO Italia
 Viale A. Volta 127/a
 50131 Firenze, Italia
 Tel: +39 800 783281
 Fax: +39 800 783282
 Email: info@imopc.it
 Web: www.imopc.it



IMO Canada
 Unit 10, Whitmore Road
 Woodbridge, Ontario.
 L4L 8G4 Canada
 Tel: +1 905 265 9844
 Fax: +1 905 265 1749
 Email: imocanada@imopc.com



- Cam Switches
- Din Terminals
- Drives
- Enclosures
- Fieldbus remote I/O
- Isolators & Switch Fuses
- MCB & RCD
- Motor Circuit Breakers
- Motor Control Gear
- Panel Meters
- Relays
- Signal Conditioning
- Sockets
- Timers
- Transformers & Power Supplies



- Drives
- Intelligent Terminals/HMI
- Limit Switches
- Photoelectric Switches
- PLCs
- Proximity Switches
- Temperature Controls



- Data Acquisition & Control
- Drives
- Intelligent Terminals/HMI
- Limit Switches
- Photoelectric Switches
- Proximity Switches
- PLCs
- Signal Conditioning
- Temperature Controls



- Lightguards
- Safety Limit Switches
- Safety Relays



- Jaguar VXM 0.37-500KW
- Jaguar VXSM 0.37-7.5KW
- Jaguar CUB 0.37-2.2KW



- Audible devices
- Chip-on-Board
- Device programmers
- LEDs & 7 seg. displays
- PCB Terminal blocks
- Relays - automotive
- Relays - power
- Relays - signal
- Switches

All IMO products are tried, tested and approved to relevant international quality standards

